

TEST SYSTEM AND PRODUCT SOLUTIONS FOR E-MOTOR TESTING

RA

RELIABLE ANALYSIS



BEYOND MEASURE.™

 **ETS·LINDGREN**[®]
An ESCO Technologies Company

ETS-LINDGREN IS AN EXPERIENCED PARTNER YOU CAN TRUST

THE LEADER IN AUTOMOTIVE TEST AND MEASUREMENT INTRODUCES ITS NEW SERIES OF E-MOTOR TESTING SOLUTIONS

ETS-Lindgren has solutions to test to a wide variety of Vehicle Component Standards:

- CISPR 25
- CISPR 12
- ISO 11452-2, -10
- ISO 7637-2, -3, -4, -7, -8
- SAE J1113/27
- ECE REG 10.6

Benefits of E-Mobile Dyno:

- CISPR 25 Compliant
- ISO 11452-2 Compliant
- High Precision HBM™ Torque Flange
- High Resolution Speed System
- Portable Design Allows for Simple Setup
- Easy Installation in Existing Chamber
- Flexible Automated Test and Control Software

ETS-Lindgren's new E-Motor Test Solutions are designed to meet the emerging requirements of e-motor performance validation and compliance testing. With system designs to support both full vehicle and Electric/Electronic Sub-Assembly (ESA) testing, these solutions provide cost effective, efficient, repeatable testing and offer full vehicle configurations that include four-wheel drive and multi-axle chassis dynamometers, fully automatic remote antenna positioning, and charging mode test setups.

Motor dyno options include the standard through shaft EMC chamber installation as described per CISPR 25 Ed. 4. This type of installation can cover the full range of motor dynamic requirements for small 20 kW motorcycle motors up to 700 kW, typical for electric motors used in commercial vehicles. An optional mobile dyno is also available for use in existing or multi-use EMC chambers where the motor dyno will not be a permanent feature of the chamber. The mobile dyno provides a limited power capacity range while offering the same full feature set and functionality associated with the fixed installation system.

Component test setups cover the full range of available e-motor torque and speed ranges for commercial and passenger vehicles, with four-quadrant operation, battery emulation, inverter emulation, and cooling options available.

ETS-Lindgren's TILE!™ (Totally Integrated Laboratory Environment) Software works seamlessly with the AVL PUMA 2™ E-Motor Dyno Control Software as well as other third-party device monitoring software. TILE! provides easy integration into your lab environment.

Standard Immunity test systems are available for test levels up to 200 V/m / 600 V/m for both full vehicle and component tests, with experienced guidance and support available for regulatory compliance.

Automotive component testing can also be accommodated in an EMC chamber designed for full vehicles. The current CISPR 25 and ISO 11452-2 standards require the use of a ground plane bench for the Device Under Test (DUT) support. This can be temporarily set up in a full sized 10-meter chamber with the necessary support equipment. To load an e-motor and inverter, a mobile motor dyno may also be brought into the chamber. The same options for coolant conditioning and battery emulation are also available for the mobile setup, with cable and communication management designed to maintain the RF integrity of the chamber setup.

E-axles are a variation of the separate e-motor drive designs seen in many first generation electric vehicles. In the latest development of the e-axle, the electric motor, transmission, and power electronics are all part of a single integrated unit with advantages in space saving, efficiency, cost, and performance. However, for EMC testing, the two output shafts provide an added complication, especially when additional controls are employed in the transmission. One solution: Use a dual-dynamometer setup to load the e-axle assembly. This solution provides for variable torque and speed with independent control for each shaft, thus remaining flexible and representative of driving conditions.



SYSTEM COMPONENT SOLUTIONS

SEMI-ANECHOIC CHAMBERS

Free-space Anechoic Chamber Test-site (FACT™) 3- and 10-meter chambers provide the test environments you need for meeting most international emissions and immunity standards for e-motor and full vehicle testing.

ANTENNAS, FIELD PROBES, AND POSITIONERS

ETS-Lindgren offers a broad line of antennas and probes. Notably, our horn, biconical, and log-periodic antennas and our E-field probes provide the repeatability and performance critical for efficient immunity and emission measurements. Additionally, ETS-Lindgren manufactures tripods, antenna towers, turntables, and test tables ideal for e-vehicle test applications. Designed with the latest test standards in mind, these positioning systems are durable, easy to operate, and low maintenance.

EMCenter™ RF TEST SYSTEM PLATFORM

EMCenter is a flexible RF test platform that includes an integrated microcontroller, touch screen, and space for up to seven mix-or-match plug-in card modules. Each card module is an instrument optimized for RF measurement.

DC SUPPLY

DC Supply options for charging test mode and support include: vehicle charging station hardware; filtered DC emulator as part of the dyno drive system to power the inverter; separate charging station emulator; AC and DC charging emulation systems up to 1,000 kW for all standard communication.

INSTRUMENTATION AND AMPLIFIERS

Your RF test system can be ordered with carefully selected EMC instrumentation and amplifiers we provide or integrated with equipment you may already have in your lab. Our large library of equipment drivers support most popular brands of new and existing instrumentation.

SOFTWARE

TILE! Software works with PUMA 2 E-Motor Dyno Control Software to provide a seamless operator interface. The TILE! interface is used to control the RF environment in an outer test loop with direct calls to PUMA 2 E-Motor software to run predefined sequences as an inner loop. All DUT monitoring is managed in the PUMA 2 environment with failures logged in the TILE! environment. ETS-Lindgren also offers VisionTRX™ Visual Monitoring System, an automated movement-based analysis of the DUT during electromagnetic testing. VisionTRX allows automated visual monitoring of relevant parameters during exposure to the required electromagnetic field strengths. The DUT may include speedometer needles, dash lights, LEDs, radios, warning displays, etc.

DYNO

We offer two primary e-motor dyno types for your test requirements: the fixed setup and the mobile setup. See page 6 for more information.

EMC SYSTEM TYPICAL CONFIGURATIONS

RADIATED EMISSIONS AND IMMUNITY TYPICAL SYSTEMS CONFIGURATION

ETS-Lindgren offers standard solutions for CISPR 25 and ISO 11452-2 testing. If a custom solution is required, ETS-Lindgren has the expertise to design and manufacture the ideal system for your project. For additional information, please visit our website at ets-lindgren.com or contact your local ETS-Lindgren representative.

EMC 3025 STANDARD SYSTEM FOR CISPR 25/ISO 11452-2

The EMC 3025 standard CISPR 25 and ISO 11452-2 test setup consists of an anechoic chamber and ground plane test bench. The minimum dimensions of the chamber are driven by the minimum test bench size as defined in the standards; the antenna sizes; and the minimum separation distance needed between the antenna and DUT, as well as from the antenna and DUT to the absorber surfaces. This arrangement is suitable for most electrical components that follow the standard layout with a DC supply fed through LISNs, connecting a module under test via an exposed length of cable harness to the actual or simulated load.

ETS-Lindgren can provide the chamber, control software, and support instrumentation for both the emission and immunity tests. Standard configurations include antennas and amplifiers to generate up to 200 V/m CW and 600 V/m pulse as part of the full system setup.

EMC 3025 TYPICAL CHAMBER LAYOUT

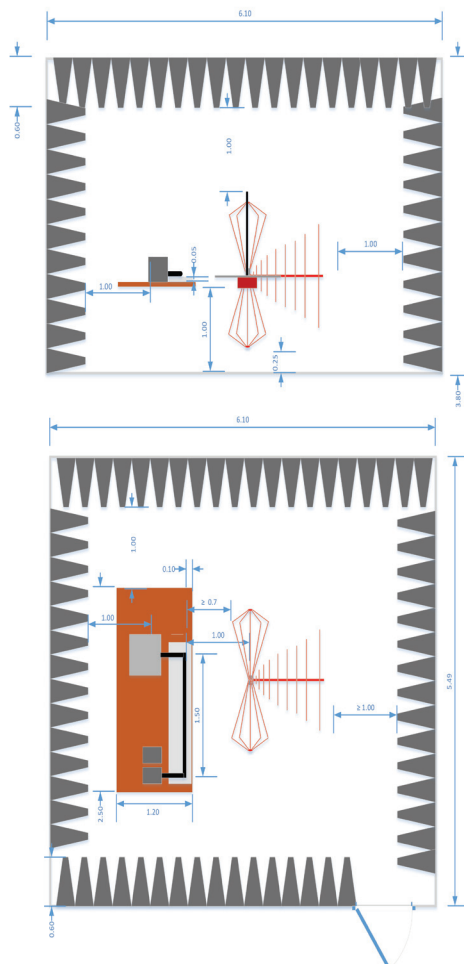

Dimensions shown on this page are in meters unless otherwise noted.



AUTOMOTIVE RADIATED EMISSIONS TYPICAL TEST SETUP

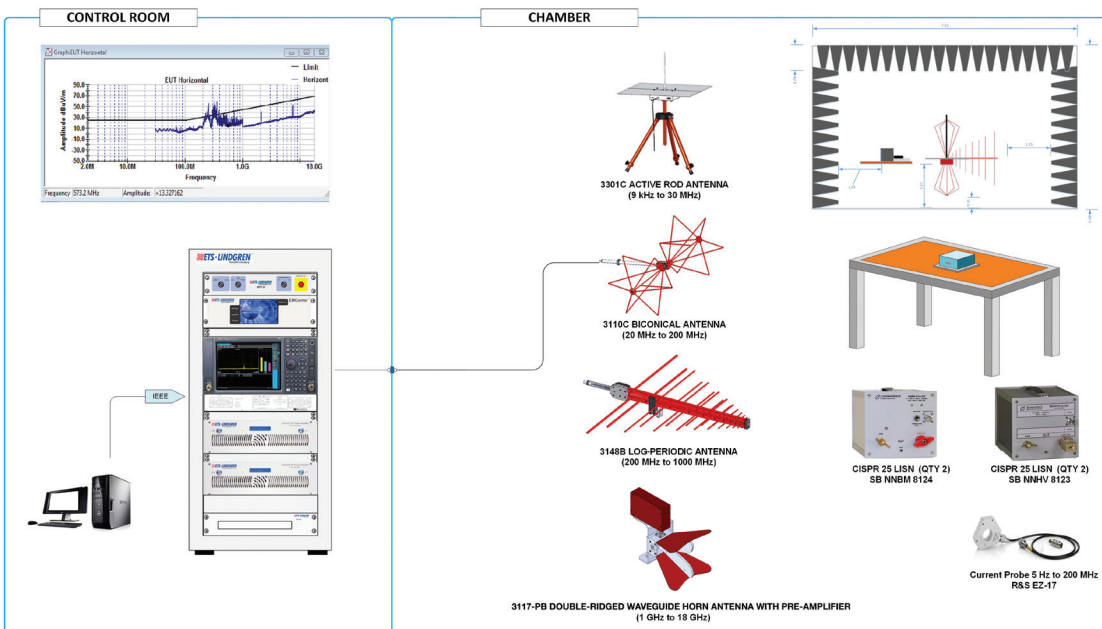

AUTOMOTIVE RADIATED IMMUNITY TYPICAL TEST SETUP

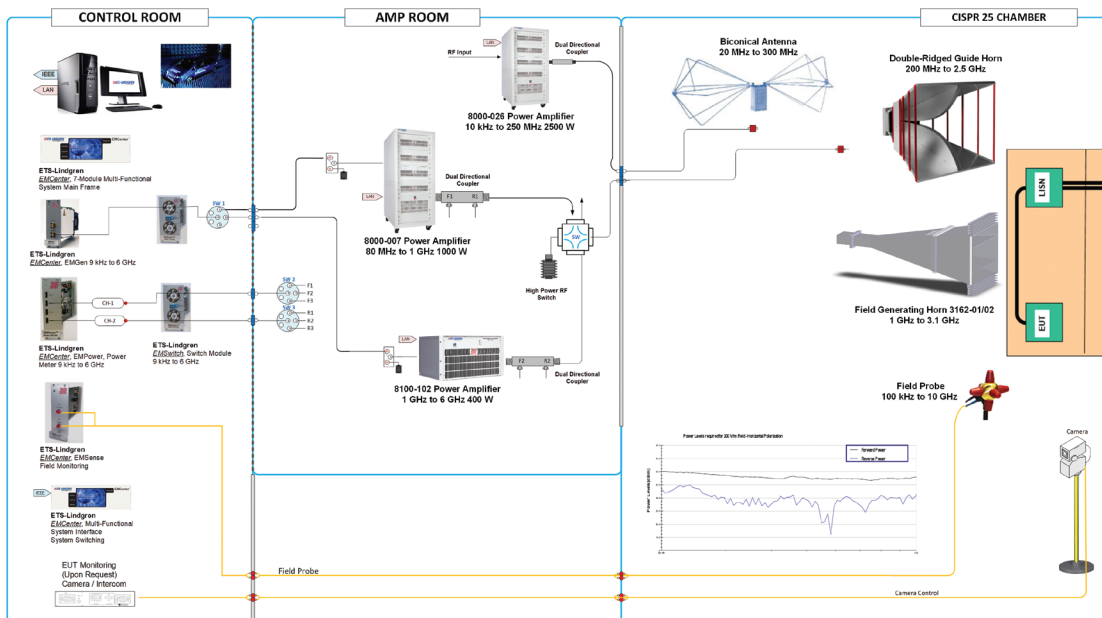

DYNO SYSTEM CONFIGURATIONS

FIXED MOTOR DYNO TYPICAL CONFIGURATION

Fixed Testbed for EMC on load testing of e-motor and inverter components

FIXED MOTOR DYNO

AVL E-Motor TS™ EMC - fixed

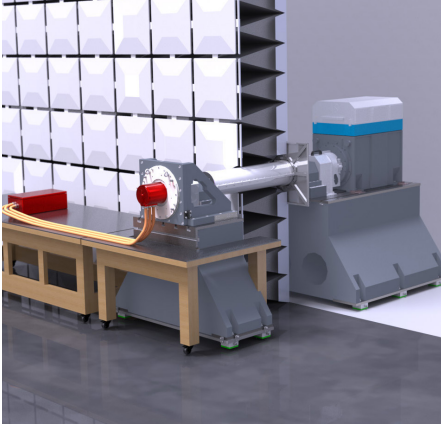

System Specifications

Item	Description
Load System	AVL DynoFORCE™, AVL DynoULTRA™
Power	Up to 700 kW
Speed	Up to 20,000 rpm with direct drive, > 20,000 rpm with gear box
Torque	Up to 4,500 Nm
Testbed Mechanics	UUT Mounting System
	Intermediate bearing, Shaft System including wall penetration
Battery Emulation	AVL E-Storage System, up to 1,000 kW, 1,200 V, 3,200 A
Coolant Conditioning System	20 kW, 50 kW
Automation and Control Software	AVL PUMA 2 E-Motor

MOBILE DYNO TYPICAL CONFIGURATION

Mobile Testbed for EMC on load testing of e-motor and inverter components

MOBILE DYNO

AVL E-Motor TS™ EMC - mobile

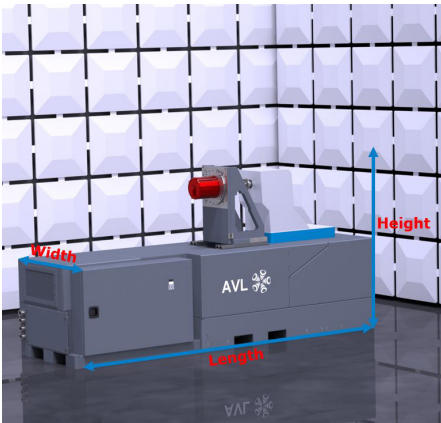

System Specifications

Item	Description
Nominal Input Voltage (V)	380 to 480 AC 50/60 Hz
Nominal Input Current (A)	216
Maximum Speed (rpm)	15,000
Nominal Speed (rpm)	3,990
Nominal Torque S1 (Nm)	228
Overload Torque (Nm)	440 Nm at 440 V
Continuous Power, S1 (kW)	95
Overload Power (kW)	162 (60 s every 300 s, recovery load ≤ 90%)
Battery Emulation	AVL E-Storage System, up to 1,000 kW, 1,200 V, 3,200 A
Coolant Conditioning System	20 kW, 50 kW
Automation and Control Software	AVL PUMA 2 E-Motor

Dimensions

Item	Description
Standard:	
Dyno Dimensions (Length x Width x Height)	2.3 m x 1.3 m x 1.6 m (7.55 ft x 4.27 ft x 5.25 ft)
Bench (Height)	0.821 m (2.69 ft)
Slim Line:	
Dyno Dimensions (Length x Width x Height)	3.3 m x 1.0 m x 1.6 m (10.83 ft x 3.28 ft x 5.25 ft)
Bench (Height)	0.821 m (2.69 ft)

EMC Parameters

Item	Description
Radiated Emissions	Frequency range 10 kHz to 18 GHz
Ground Noise	10 dB less than the CISPR 12 broadband transient emissions At least 10 dB better than class 5 according to CISPR 25 Ed. 4
Immunity Field	> 300 V/m

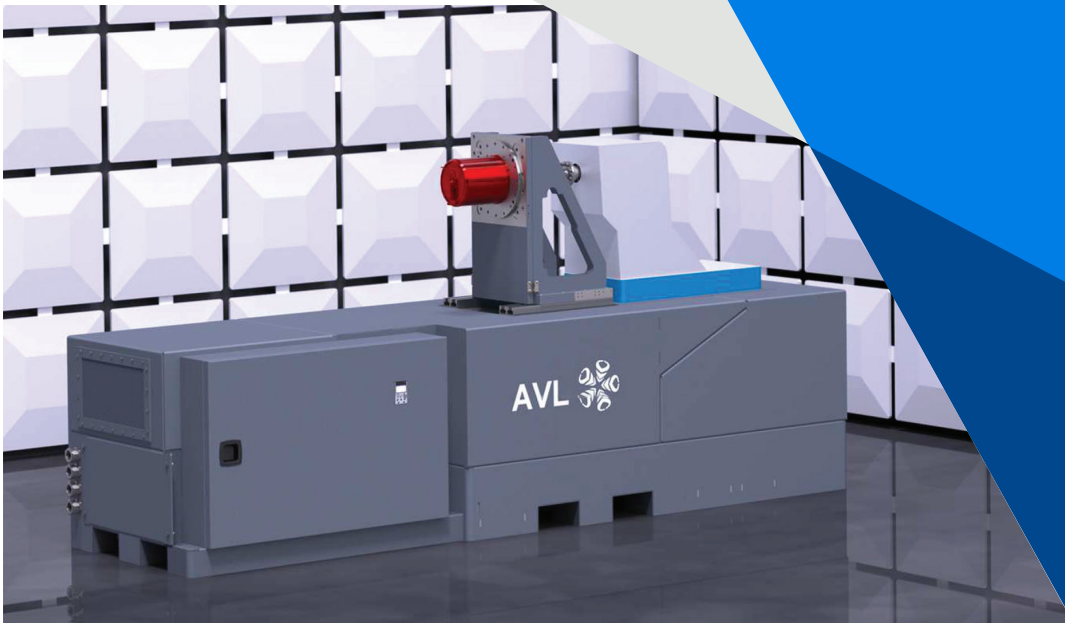

FIXED INSTALLATION VS. MOBILE DYNO

Fixed Installation

Pros	Cons
Standard or custom sized chamber to match maximum DUT	Larger than minimum sized chamber for CISPR 25/ISO 11452-2 tests required
Dyno and support cabinets to match maximum drive capacity permanently installed	Limited to maximum capacity
Fixed stable supports for maximum speed and torque	Modified installation and supports needed
One or more dynos can be permanently installed for different e-drive configurations	Custom chamber design needed for e-axle configurations
Fixed or adjustable height / mounting of e-motor	Potentially larger, more complex platform required
Increased flexibility in test capability and capacity	Potentially higher in cost than mobile upgrade option in an existing chamber
All required inverter drives and conditioning units permanently installed outside the chamber	Additional space needed outside the chamber for drive cabinet, DC emulator, and coolant conditioner
Higher field levels can be accommodated inside the chamber	

Mobile Dyno

Pros	Cons
Full sized chamber available for full vehicle or component testing	Only module testing or full vehicle testing can be accommodated at one time
Easy changeover for module test setup	Setup time needed for changeover
Unit selection based on required capacity	Limited maximum speed and torque
Cables can be permanently routed below floor	Added access to cable connection points needed
Easily movable	Pallet truck or forklift needed for movement
Potentially lower mobile upgrade cost than fixed installation	Limited flexibility in test capabilities
Built-in dyno inverter drives and conditioning	Capacity limited to installed components
Can be used on an optional turntable for R & D 360° measurements	
Can be used as upgrade in existing EMC chambers thanks to the narrow design (<1 m width)	

E-MOTOR AND E-AXLE CONFIGURATIONS

EMC 3025-E E-MOTOR SYSTEM FOR CISPR 25/ISO 11452-2

The EMC 3025-E e-motor system differs from the standard setup with the addition of the motor dynamometer, which acts as a load for the motor and inverter under test. Drive components typically operate at much higher voltages than the 12 V DC used in standard electronics, so additional precautions are needed to reduce the risk of electric shock. However, the primary differences between it and the EMC 3025 are the added motor dyno and its support equipment. These components allow the motor and inverter to be run under full load conditions in both the drive mode and regen mode, which simulates conditions during which the inverter is powering the motor, as well as when the inverter is charging the battery.

EMC 3025-E TYPICAL CHAMBER LAYOUT

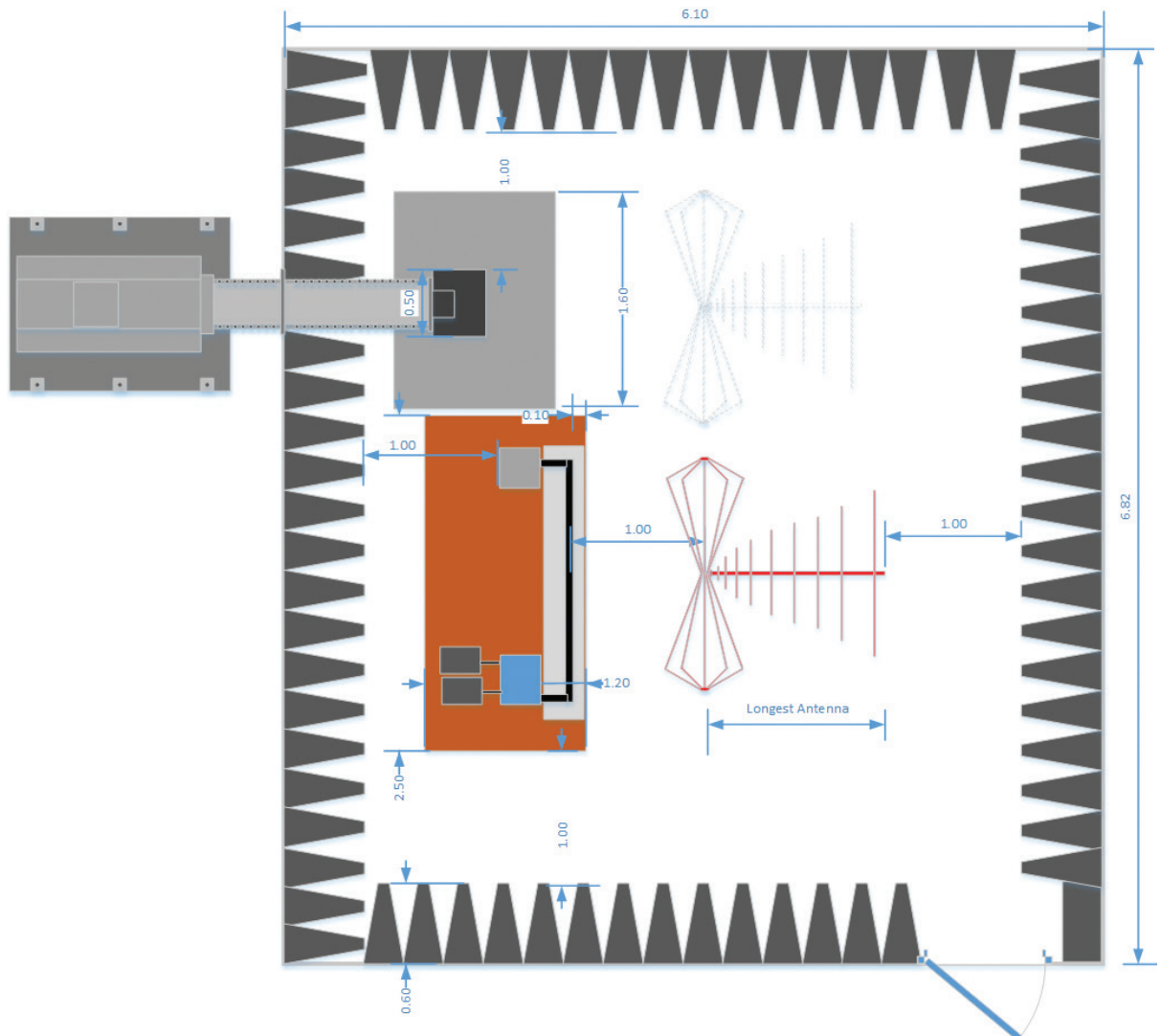

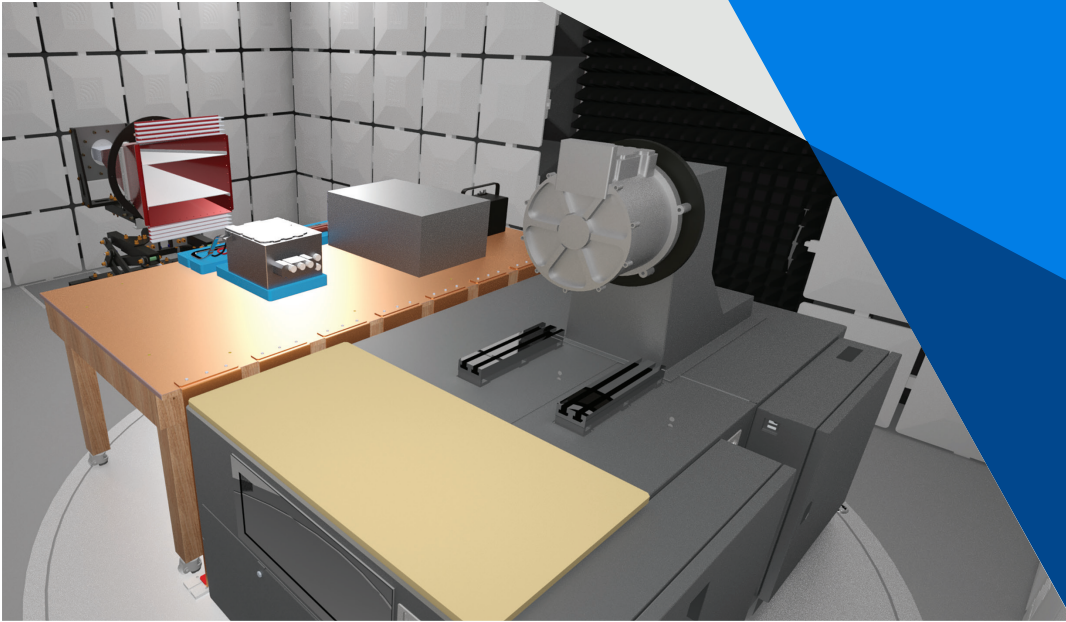

EMC 3025-EX E-AXLE SYSTEM FOR CISPR 25/ISO 11452-2

The EMC 3025-EX e-axle system is a highly customized solution in which the overall chamber dimensions will be determined by the range of sizes and performance of the e-axle units to be accommodated.

The primary separation requirements for the antennas and DUT remain the same, as do the test and measurement support instruments, but the mechanical support needed for the e-axle and the connecting bearings varies with the maximum speed and torque to be supported.

This EMC chamber can also be designed to accommodate both a single motor and e-axle setup with the test bench oriented in a right-angle arrangement.

EMC 3025-EX TYPICAL CHAMBER LAYOUT

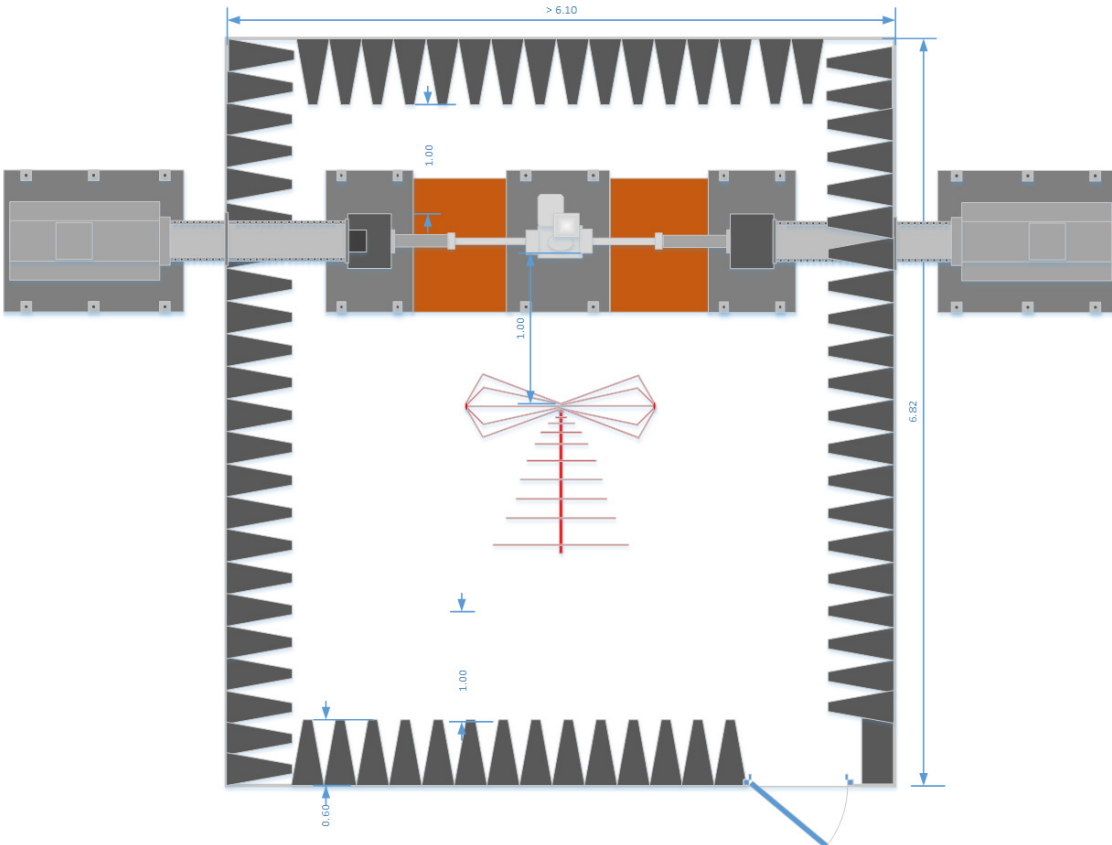

MOBILE DYNO CONFIGURATIONS

EMC 3025-EM E-MOTOR MOBILE DYNO SYSTEM FOR CISPR 25/ISO 11452-2

The EMC 3025-EM mobile dyno system rounds out the dyno options for supporting e-vehicle component EMC testing. The free-standing mobile unit contains the AVL E-Motor TS EMC - mobile dyno with drive electronics and controls in a shielded enclosure supporting full 4Q operation. The complete test setup supports the current emission and immunity standards without compromising the quality of the measurement environment.

The primary benefit of the AVL E-Motor TS EMC - mobile dyno is the ability to perform e-component testing in an existing EMC chamber designed for full vehicle or consumer electronics without major modification. The majority of these chambers already have a raised floor and turntable and can easily accommodate the routing of interconnecting power cables and signal fiber optics below the floor void.

The efficiency of operation can be further enhanced if the DUT is set up on the mobile dyno outside the EMC chamber. The complete ready-to-test assembly can then be moved into the chamber using a standard pallet truck and connected to the supply power.

The modular nature of the mobile platform allows customization to accommodate a larger, higher capacity dyno motor and drive for higher speed or torque test support.

Typically included in the EMC 3025-EM system are:

- Upgraded Component Package to Meet CISPR 25 Ed. 4
- Mobile E-Motor Dyno with Integrated Software Package
- Pre- and Post-Chamber Validation Tests
- Project Management, including System Integration
- Software and Hardware System Training

EMC 3025-EM TYPICAL CHAMBER LAYOUT

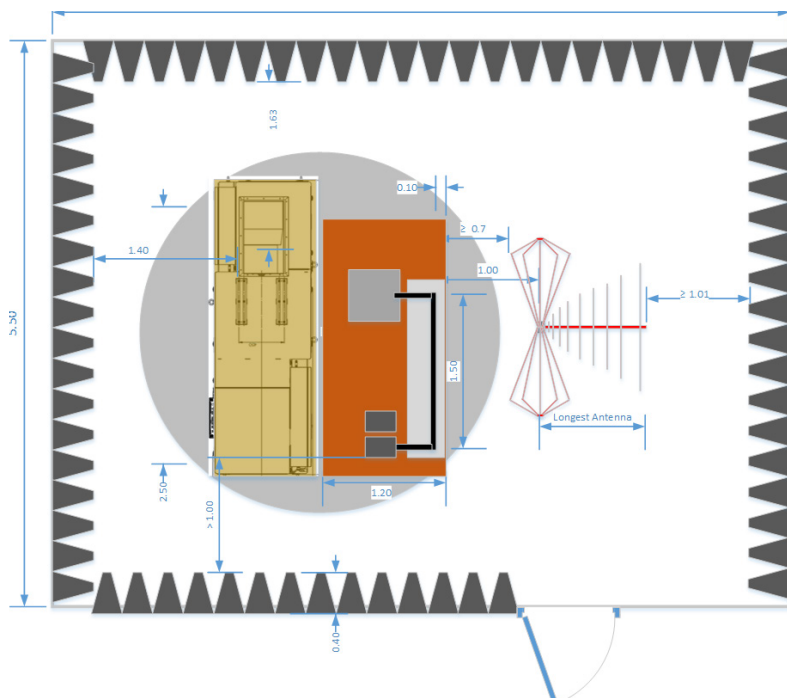

Dimensions shown on this page are in meters unless otherwise noted.



SYSTEM CONTROL SOFTWARE

- TILE!
- PUMA 2
- VisionTRX

The control software is a key component in the overall measurement system, whose primary function is to support the emission and immunity testing of the electric/electronic components (DUT).

IMMUNITY AND EMISSIONS TESTS

TILE! EMC control software manages the test by controlling the test instruments; setting test frequency, field strength, and modulation; and recording significant events.

PUMA 2 E-Motor software manages the control of the dyno while loading the DUT during the test and provides continuous monitoring to the electrical and mechanical parameters of the dyno hardware to ensure precise load control.

The VisionTRX extension to TILE! provides powerful video monitoring of the DUT using sophisticated algorithms to detect visual failure cues of components selected on a camera image. The automated visual monitoring capabilities of VisionTRX reduce the potential for human error common with this type of tedious review.

There are direct communication links and calls between the TILE!, PUMA 2, and VisionTRX software packages to create a seamless test sequence managed by TILE!, with full control for all aspects for both immunity and emission tests.

Sales and Support Offices

UNITED STATES – TEXAS

Cedar Park, TX

+1.512.531.6400 Phone

+1.512.531.6500 Fax

info@ets-lindgren.com

UNITED STATES – ILLINOIS

Wood Dale, IL

+1.630.307.7200 Phone

+1.630.307.7571 Fax

info@ets-lindgren.com

UNITED STATES – WISCONSIN

Minocqua, WI

+1.715.356.2022 Phone

+1.715.356.2023 Fax

info@ets-lindgren.com

FINLAND

Eura

+358.2.8383.300 Phone

+358.2.8651.233 Fax

euinfo@ets-lindgren.com

CHINA

Beijing

+86(10)8273.0877 Phone

+86(10)8273.0880 Fax

china@ets-lindgren.com

JAPAN

Tokyo

+81.3.3813.7100 Phone

+81.3.3813.8068 Fax

japan@ets-lindgren.com

INDIA

Bangalore

+91.80.4341.8600 Phone

+91.80.4341.8611 Fax

indiainfo@ets-lindgren.com

SINGAPORE

Singapore

+65.6391.0026 Phone

+65.6291.7311 Fax

singapore@ets-lindgren.com

TAIWAN

Taipei

+886.2.27023389 Phone

+886.2.27023055 Fax

taiwan@ets-lindgren.com

BEYOND MEASURE.



An ESCO Technologies Company

ets-lindgren.com